

# 635nm/10mW Circular Beam Laser Diode

## CircuLaser™ Laser Diode

Circular beam with diffraction-limited performance and low divergence in a standard package

- 10mW Optical Power
- Built-in Monitor Photodiode
- Circular, diverging beam with  $\mu$ Lens™ technology
- Numerical Aperture (NA) ~0.11
- Aberration ~1/4 peak to valley
- AlGaInP index-guided, MQW Laser Diode
- Hermetically sealed package
- Standard 9mm, and 5.6mm package



### Absolute Maximum Ratings (case temperature = 25°C)

Parameter	Symbol	Minimum	Maximum	Unit
Optical Output Power	$P_o$	-	10	mW
LD Reverse Voltage	$V_R$ (LD)	-	2	V
PD Reverse Voltage	$V_R$ (PD)	-	30	V
Operating Temperature	$T_{opr}$	-10	+50	°C
Storage Temperature	$T_{stq}$	-40	+85	°C

### Optical and Electrical Characteristics (case temperature = 25°C)

Parameter	Symbol	Minimum	Typical	Maximum	Unit	Test Conditions
Threshold Current	$I_{th}$	-	40	60	mA	
Operating Current	$I_{op}$	-	55	75	mA	$P_o = 10mW$
Operating Voltage	$V_{op}$	-	2.2	2.4	V	$P_o = 10mW$
Optical Output Power	$T_{opr}$	-		10	mW	Kink free
Slope Efficiency	$\eta$	0.4	0.65	0.90	mW/mA	$P_o = 10mW$
Wavelength	$\lambda$	630	635	640	nm	$P_o = 10mW$
Circularity	$\phi$		-	1.2:1.0	Ratio	$P_o = 10mW$
Beam Divergence	$\theta$	6	8	11	Deg	$P_o = 10mW$ , FWHM
Off axis Angle	$\Delta\theta$	-	-	$\pm 3$	Deg	
Monitor Current	$I_s$	0.04	0.08	0.16	mA	$P_o = 10mW$ $V_R$ (PD)=5V
Astigmatism	$A_s$	-	-	0.25	Waves	

Specifications are subject to change without notice.  
Each CircuLaser is provided with test data.

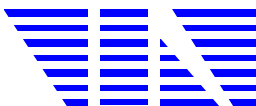

VIN KAROLA INSTRUMENTS

P.O. Box 922273  
Norcross, GA 30010-2273  
Tel: 770/409-1499  
Fax: 770/447-8045  
e-mail: info@vinkarola.com

Circularity, Beam quality, and Beam divergence..... All in one

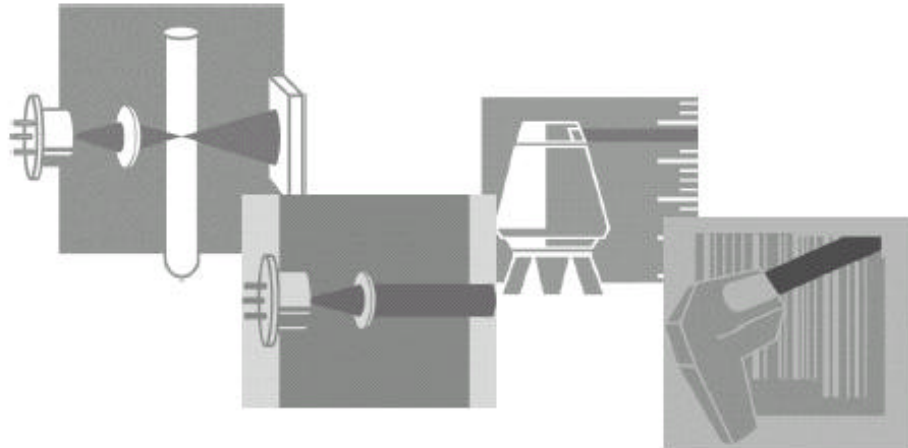

Pin-Out Chart

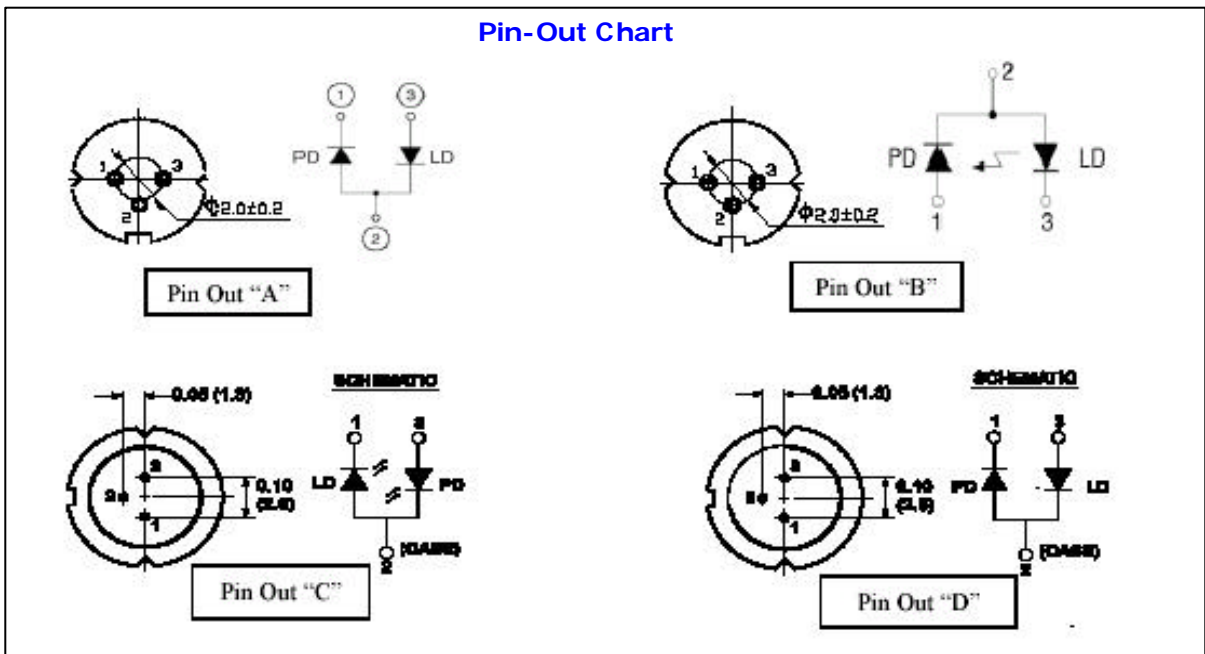

Mechanical Package and Layout  
(TO-5.6 package shown)

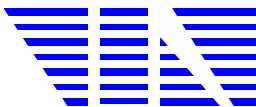
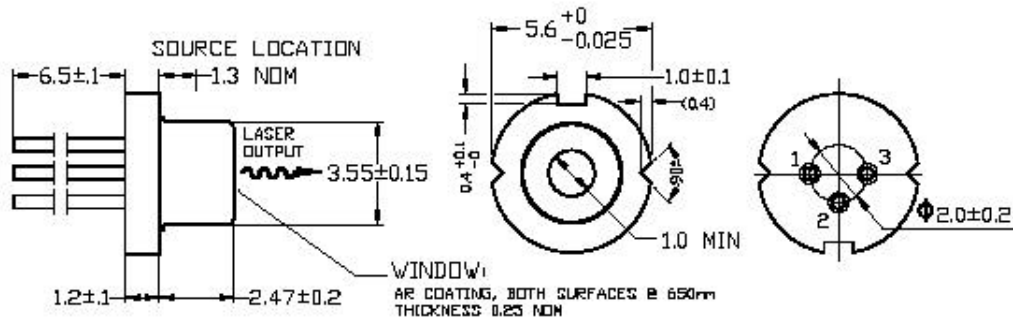

VIN KAROLA INSTRUMENTS

P.O. Box 922273  
Norcross, GA 30010-2273  
Tel: 770/409-1499  
Fax: 770/447-8045  
e-mail: info@vinkarola.com